

# General Specifications

Model UT321  
Digital Indicating Controller  
with Active Color PV Display



GS 05D01D12-02E

## General

Model UT321 Digital Indicating Controller is a precision 1/8 DIN controller, provided with the PV display color changing function "Active Color PV Display." It has a large display for readings, universal input/output and excellent monitoring operability with the Auto/Man switching key. In addition, auto tuning, the overshoot suppressing function "SUPER", the hunting suppressing function "SUPER2" and heating/cooling control are available as control functions, and a re-transmission output and 15 V DC loop power supply are also equipped as standard. A communication function or 24 V DC loop power supply is available optionally. As described above, the UT321 is a controller provided with higher functions and capability.

## Main Features

- Extra-large digital display allows the indicated values to be read even from a long distance. LEDs of 12 mm height are used for the PV display.
- The PV display color changing function "Active Color PV Display" is provided. PV display color is changed from green to red and vice versa when an alarm occurs or deviation becomes large. The color also can be fixed in green or red.
- Universal input and output allow simple setting of the input type (thermocouple, RTD or mV), PV input range, and type of control output (4 to 20 mA current, voltage pulse, or relay contact) from the front panel.
- Parameters can easily be set using a personal computer. ("Parameter setting tool (model LL100)" sold separately is required.)
- Various communication functions are provided. Communication is possible with personal computer, programmable logic controller, and other controllers.

## Functional Specifications

### Control Computation Functions

Control computation:

Can be selected from the following types:  
Continuous PID control, Time-proportional PID control, Heating/Cooling control (for heating/cooling type only) or Relay ON/OFF control.

Control cycle time: 250 ms

Number of sets of target setpoints and PID parameters: 4

Target setpoint and PID selection:

PID parameters are provided for every target setpoint and the set of PID parameters are selected at the same time that the setpoint number is selected.

Zone PID selection:

PID parameters are selected depending on the value of the PV. For selection, the reference point (PID parameter selection setpoint) or the reference deviation is used.

### UT321



### UT321E

"E" indicates the model with expanded functions.

Reference point method:

The PV input range is divided into a maximum of three zones with up to two reference points, and PID parameters are selected (No. 1 PID to No. 3 PID) for every zone.

Reference point = PV input range (0%)  $\leq$   
Reference point 1  $\leq$  Reference point 2  $\leq$   
PV input range (100%)

Reference point hysteresis = Fixed to 0.5% of the PV input range span.

Reference deviation method:

PID parameters (No. 4 PID) are selected when the deviation exceeds the reference deviation. This method takes precedence over the reference point method.

Reference deviation = OFF or 0.1 to 100.0% of PV input range span

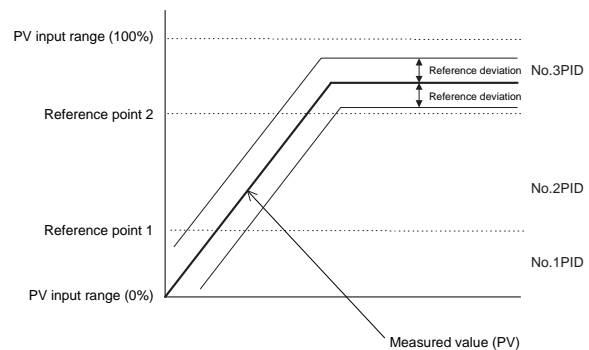

Auto-tuning:

Available as standard. If auto-tuning is operated, PID constants are automatically set (limit cycle method).

"SUPER" function:

Overshoots generated by abrupt changes in the target setpoint or by disturbances can be suppressed.

**“SUPER2” function:**

The function stabilizes the state of control that is unstable due to hunting, etc. without requiring any change in PID constants, when the load and/or gain varies greatly, or when there is a difference between the characteristics of temperature zones.

**Control Parameters Setting Range**

Proportional band = 0.1 to 999.9%

0.0 to 999.9% for heating/cooling control,  
0.0% for ON/OFF control

Integral time = 1 to 6000 s, or OFF (manual reset)

Derivative time = 1 to 6000 s, or OFF

Manual reset value = -5.0 to 105.0% of output range  
(Functions when integral time is off.)

ON/OFF control hysteresis = 0.0 to 100.0% of PV input range span (0.1 to 0.5% for heating/cooling control)

Setpoint rate-of-change setting = OFF, or 0.0 to 100.0%/h or min of PV input range span  
A PV tracking function operates automatically when the setpoint is changed, the power is turned on, or the mode is changed from manual to automatic.

Direct/reverse action:

The output increase/decrease direction can be defined corresponding to a positive or negative deviation.  
For heating/cooling control, it is fixed; reverse for the heating-side output, direct for the cooling-side output.

Anti-reset windup:

When controller output is limited, normal integration is superseded by an anti-reset windup computation to suppress over-integration.

Control output cycle time = 1 to 1000 s for Time-proportional PID control (The cooling-side output cycle time is also the same when heating/cooling control is used.)

Preset output value = -5.0 to 105.0% of output range

Output tracking=Whether the output bump is provided or not can be selected by changing the PID control mode.

Output limiter

Upper limit = Lower limit to 105.0% of output range  
Lower limit = -5.0% of output range to upper limit

Heating/cooling dead band = -100.0 to 50.0% for output range

**● Signal Computation Functions**

PV input computation:

Bias addition (-100.0 to 100.0% of PV input range span), and first-order lag filter (time constant OFF or 1 to 120 s)

Contact input function:

Target setpoint selection, Auto/Man operating mode switching, key lock parameter show/hide switching  
Target setpoint selection can be done for either a 2-setpoint or 4-setpoint selection.  
• If the 2-setpoint selection is set, Auto/Man mode switching can be used as well.  
• If the 4-setpoint selection is set, Auto/Man switching and key lock parameter show/hide switching cannot be used together.

If key lock parameter show/hide switching is used, target setpoint selection and Auto/Man mode switching cannot be used.

**● Alarm Functions**

Twenty-four types of alarm functions are provided. The alarm status is indicated by the alarm lamp on the front panel. Also, three points among them can be output as relay contact outputs.

Alarm types:

PV high limit, PV low limit, Deviation high limit, Deviation low limit, De-energized on deviation high limit, De-energized on deviation low limit, Deviation high and low limits, High and low limits within deviation, De-energized on PV high limit, De-energized on PV low limit, SP high limit, SP low limit, Output high limit, Output low limit, Deviation high limit for target setpoint, Deviation low limit for target setpoint, De-energized on deviation high limit alarm for target setpoint, De-energized on deviation low limit alarm for target setpoint, Deviation high and low limits for target setpoint, Deviation within high and low limits for target setpoint, Heater burnout alarm, Sensor grounding alarm, Fault diagnostic alarm, and FAIL output.

Alarm output:

3 points. Any three points among the above alarms can be output as contact outputs. For heating/cooling control, if cooling-side output is output as a relay contact, up to two alarm outputs can be used.

Setting ranges for PV, deviation, setpoint and output alarms:

PV/setpoint alarm:

-100.0 to 100.0% of PV input range

Deviation alarm:

-100.0 to 100.0% of PV input range span

Output alarm:

-5.0 to 105.0% of output range

Alarm hysteresis:

0.0 to 100.0% of PV input range span

Delay timer:

0.00 to 99.99 (minute, second)

An alarm is output when the delay timer expires after the alarm setpoint is reached. Setting for each alarm is possible.

Stand-by action:

Stand-by action can be set to make PV/deviation alarm OFF during start-up or after SP change until SP reaches the normal region.

Heater burnout alarm (optional):

Two circuits incorporated.

A heater burnout alarm is output if the heater current consumption is the burnout detection value or less. This alarm can be used for Relay ON/OFF control or time-proportional PID control.

Heater current setting range: 0.0 to 50.0 A

Heater current measuring accuracy:  $\pm 5\%$  of span  $\pm 1$  digit

Heater current detecting resolution: 0.5 A

Time required until burnout detection is on: 0.13 s minimum

Burnout sensor model: CTL-6-S-H (URD Co. Ltd.)

Burnout sensor is provided separately.

Sensor grounding alarm:

An alarm is output after detecting a change in control output. If the moving average \* of control output is out of the setting range (between the high and low limits of the on/off rate) in spite of the deviation being within a fixed range (on/off rate detection band) and control being in stable condition, the sensor is judged to be in a grounding condition.

\* Moving average refers to the average value for output values sampled (five times) in every cycle time.

High- and low-limit setting range of on/off rate: -5.0 to 105.0% of output range

Detection band of on/off rate: 0.0 to 100.0% of PV input range span

Fault diagnostic alarm:

Input burnout, A/D conversion error, thermocouple RJC error

FAIL output: Abnormality in software or hardware.

When in Fail status, control output, retransmission output and alarm output become 0% or OFF.

● Display and Operation Functions

PV display: 4-digit digital display for engineering data

Setpoint display:

Various data, such as the setpoint (SP), are displayed by selection on the 4-digit digital display.

Status indication:

Alarm indicator lamp

3 lamps: AL1, AL2 and AL3

Setpoint number indicator lamp:

3 lamps: SP2, SP3 and SP4 (not lit when SP1 is selected)

MAN operation mode lamp: MAN (lit in MAN mode)

PV display color changing function "Active Color PV Display":

(Factory-set default : Fixed in red mode)

This function automatically changes PV display color by the action described below. Green-to-red or red-to-green changing action is selectable.

Link to alarm 1 mode :

Alarm OFF : green, Alarm ON : red  
Setting of Alarm OFF : red, Alarm ON : green is possible.

Link to alarms 1 and 2 mode :

Alarm OFF : green, Alarm ON : red  
Setting of Alarm OFF : red, Alarm ON : green is possible.

SP deviation mode :

Within the preset SP deviation : green,  
Out of the preset SP deviation : red  
Setting of within the preset SP deviation : red, Out of the preset SP deviation : green is possible.

Deviation band is changeable using a parameter. The setting of either high limit deviation or low limit deviation is also possible.

PV limit mode :

Within the preset PV range : green,  
Out of the preset PV range : red  
Setting of Within the preset PV range : red, Out of the preset PV range : green is possible.

The range (high limit and low limit) is changeable using a parameter.

Fixed color mode :

PV display color is fixed in green or red.

Operation keys:

△ and ▽ keys:

Increase or decrease setpoints and various parameters.

SET/ENT key:

Sets setpoint data, calls or selects various parameters during operation.

A/M key:

Switches operation mode (Auto/Man)

SELECT display:

Allows selection and registration of frequently changed parameters from the operating parameters during operation.

For example, if the alarm-1 setpoint is registered in the SELECT display, the setpoint can easily be displayed during operation.

Security function:

Operation can be inhibited by a password.

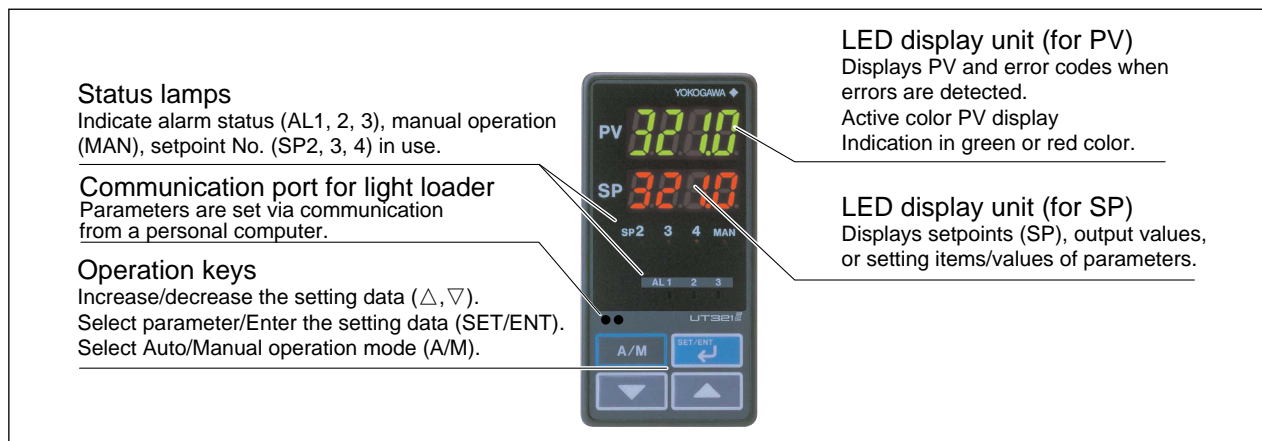

● **Communication Functions (Optional Function )**

The communication function, provided with the instrument, allows connection to a personal computer, programmable logic controller, and other controllers.

Communication protocol

Computer link communication:

Communication protocol with a personal computer.

Ladder communication:

Communication protocol with programmable logic controllers.

MODBUS communication:

Communication protocol with a personal computer or PLC.

Coordinated operation:

Communication protocol for coordinated operation with two or more GREEN series controllers. The UT321 can be connected as a master station or a slave station.

Communication interface

Communication protocol:

Computer link, ladder communication, MODBUS communication or coordinated operation

Standards: EIA RS-485

Maximum number of connectable controllers:

31 GREEN series controllers

Maximum communication distance: 1,200 m

Communication method:

Two-wire half duplex or four-wire half-duplex, start-stop synchronization, non-procedural

Communication rate:

600, 1200, 2400, 4800, or 9600 bps

Examples of Communication System Configuration Diagram

(1) Computer link communication/MODBUS communication

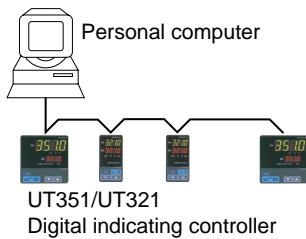

(2) Ladder communication

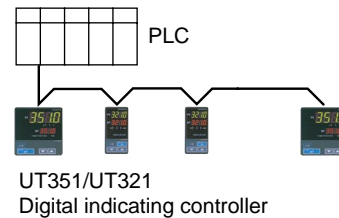

(3) Coordinated operation

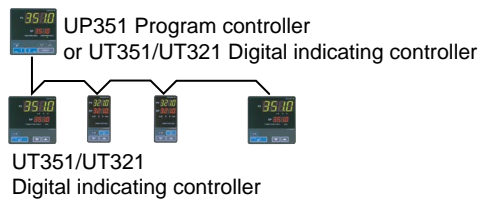

## ■ Hardware Specifications

### PV Input Signal

Number of input points: 1

Input system:

The type of input and instrument range can be specified using the table of PV input shown below by key operation or communication.

Sampling period: 250 ms

Input type, instrument range and measurement accuracy:

Refer to the table below.

Input type		Input range code	Instrument range (°C)	Instrument range (°F)	Measurement accuracy*1
Unspecified(when shipped from the factory)		OFF	Set the data item PV input Type"IN" to the OFF option to leave the PV input type undefined.		
Thermocouple	K	1	-200 to 1370°C	-300 to 2500°F	±0.1% of instrument range ± 1 digit for temperatures equal to or higher than 0 °C, ±0.2% of instrument range ± 1 digit for temperatures below 0 °C
		2	-199.9 to 999.9°C	0 to 2300°F	
		3	-199.9 to 500.0°C	-199.9 to 999.9°F	
	J	4	-199.9 to 999.9°C	-300 to 2300°F	
	T	5	-199.9 to 400.0°C	-300 to 750°F	
		6	0.0 to 400.0°C	-199.9 to 750.0°F	
	B	7	0 to 1800°C	32 to 3300°F	±0.15% of instrument range ± 1 digit for temperatures equal to or higher than 400 °C ± 5% of instrument range ± 1 digit for temperatures below 400 °C
	S	8	0 to 1700°C	32 to 3100°F	±0.15% of instrument range ± 1 digit
	R	9	0 to 1700°C	32 to 3100°F	
	N	10	-200 to 1300°C	-300 to 2400°F	±0.1% of instrument range ± 1 digit ±0.25% of instrument range ± 1 digit for temperature below 0 °C
	E	11	-199.9 to 999.9°C	-300 to 1800°F	±0.1% of instrument range ± 1 digit for temperatures equal to or higher than 0 °C
	L (DIN)	12	-199.9 to 900.0°C	-300 to 1300°F	
	U (DIN)	13	-199.9 to 400.0°C	-300 to 750°F	±0.2% of instrument range ± 1 digit for temperatures below 0 °C
		14	0.0 to 400.0°C	-199.9 to 750.0°F	
	W (DIN)	15	0 to 2300°C	32 to 4200°F	±0.2% of instrument range ± 1 digit
	Platinel 2	16	0 to 1390°C	32 to 2500°F	±0.1% of instrument range ± 1 digit
	PR20-40	17	0 to 1900°C	32 to 3400°F	±0.5% of instrument range ± 1 digit for temperatures equal to or higher than 800 °C No guarantee of accuracy for temperatures below 800 °C
	W97Re3-W75Re25	18	0 to 2000°C	32 to 3600°F	±0.2% of instrument range ± 1 digit
RTD	JPt100	30	-199.9 to 500.0°C	-199.9 to 999.9°F	±0.1% of instrument range ± 1 digit (Note 1) (Note 2)
		31	-150.0 to 150.0°C	-199.9 to 300.0°F	±0.2% of instrument range ± 1 digit (Note 1)
	Pt100	35	-199.9 to 850.0°C	-300 to 1560°F	±0.1% of instrument range ± 1 digit (Note 1) (Note 2)
		36	-199.9 to 500.0°C	-199.9 to 999.9°F	
		37	-150.0 to 150.0°C	-199.9 to 300.0°F	±0.2% of instrument range ± 1 digit (Note 1)
Standard signal	0.4 to 2 V	40	0.400 to 2.000	Scaling is enable in the following 4 range. -1999 to 9999	±0.1% of instrument range ± 1 digit The read-out range can be scaled between -1999 and 9999.
	1 to 5 V	41	1.000 to 5.000		
DC voltage	0 to 2 V	50	0.000 to 2.000		
	0 to 10 V	51	0.00 to 10.00		
	-10 to 20 mV	55	-10.00 to 20.00		
	0 to 100 mV	56	0.0 to 100.0		

Note 1: The accuracy is ±0.3°C of instrument range ± 1 digit for a temperature range from 0 to 100°C.

Note 2: The accuracy is ±0.5°C of instrument range ± 1 digit for a temperature range from -100 to 0°C and 100 to 200°C.

\*1: Performance in the standard operating condition (at 23°C ± 2°C, 55 ± 10%RH, and 50/60Hz power frequency)

\*2: To receive a 4 to 20 mA DC signal, select a Standard signal of 1 to 5 V DC and connect it to a 250 Ω resistor.

This resistor is optional Model: X010-250-2 (resistor with M3.5 crimp-on-terminal lugs)

Burnout detection:

Functions at thermocouple (TC), RTD or standard signal of 0.4 to 2 V or 1 to 5 V.  
Upscale, downscale, and off can be specified.  
For standard signal, set to burnout at 0.1 V or less.

Input bias current: 0.05 µA for TC and RTD b-terminal

Measurement current(RTD): About 0.13 mA

Input resistance:

1 MΩ or more for TC or mV input  
About 1 MΩ for DC voltage input  
Allowable signal source resistance:  
250 Ω or less for TC or mV input  
Effects of signal source resistance:  
0.1 µV/Ω or less  
2 kΩ or less for DC voltage input  
Effects of signal source resistance:  
About 0.01%/100 Ω



- Allowable wiring resistance:
  - Max. 150 Ω/wire (resistance in each of three wires must be equal) for RTD input
  - However, max. 10 Ω/wire for the range of -150.0 to 150.0°C.
  - Wiring resistance effect: ±0.1°C/10 Ω
- Allowable input voltage:
  - ±10 V DC for TC, mV or RTD input
  - ±20 V DC for DC voltage input
- Noise rejection ratio:
  - Normal mode 40 dB (50/60 Hz) or more
  - Common mode 120 dB (50/60 Hz) or more
- Reference junction compensation error:
  - ±1.0°C (15 to 35°C),
  - ±1.5°C (0 to 15°C, 35 to 50°C)
- Applicable standards:
  - JIS, IEC, or DIN (ITS-90) for TC and RTD
- Response time: 2 second or less, 63% (10 - 90%)
  - (The time required for transmission output to reach 63% of the maximum excursion when PV abruptly changes from 10% to 90%)

**24 V DC Loop Power Supply for Sensor**

Supplies power to a two-wire transmitter. A resistor (10 to 250Ω) connected between the controller and the transmitter converts a current signal into a voltage signal, which is then read by the PV input terminal.

Supply voltage: 21.6 to 28.0 V DC  
 Maximum supply current : 30 mA (only for models with 24 V DC loop power supply)  
 Ambient temperature should be 0 to 40°C when using 24 V DC loop power supply for UT321.

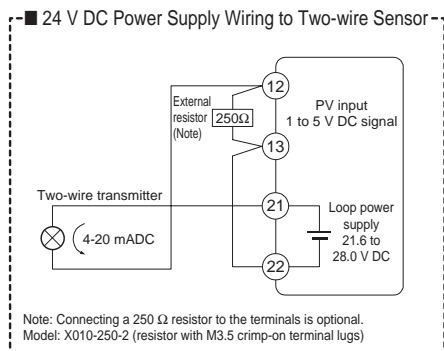

**Retransmission Output**

Any of PV, target setpoint, or control output is output. Can also be used for 15 V DC loop power supply.

- Number of output points: 1
- Output signal: 4 to 20 mA DC
- Load resistance: 600 Ω or less
- Output accuracy: ±0.3% of span
  - Performance in the standard operating conditions (at 23± 2°C, 55± 10% RH, and 50/60 Hz power frequency)

When used for 15 V DC loop power supply:

- Supply voltage: 14.5 to 18.0 V DC
- Maximum supply current : About 21 mA (with the protection circuit at field short circuit).

**Control Outputs**

The control output is of a universal scheme and can be selected from the following types of outputs. In the case of heating/cooling control, it is also selectable from these outputs. However, if the cooling-side output is a relay contact output, the alarm-3 cannot be used, and similarly if

the cooling-side output is a voltage pulse or current output, the retransmission output (15 V DC loop power supply) cannot be used.

- Current output
  - Number of output points: 1 or 2 (2 for heating/cooling type)
  - Selected between voltage pulse output.
  - Output signal: 4 to 20 mA DC
  - Load resistance: 600 Ω or less
  - Output accuracy: ±0.3% of span
    - Performance in the standard operating conditions (at 23± 2°C, 55± 10% RH, and 50/60 Hz power frequency)
- Voltage pulse output
  - Number of output points: 1 or 2 (2 for heating/cooling type)
  - Selected between current output.
  - Output signal:
    - On voltage = 12 V DC or more (load resistance; 600 Ω or more, current at short-circuit; about 30 mA)
    - Off voltage = 0.1 V DC or less
  - Resolution: 10 ms
- Relay contact output
  - Number of output points: 1 or 2 (2 for heating/cooling type)
  - Output signal:
    - At three terminals of NC, NO and Common, transfer-contact
  - Contact rating:
    - 250 V AC, 3 A or 30 V DC, 3 A (resistive load)
  - Resolution: 10 ms

**Contact Inputs**

- Usage: Target setpoint selection, Auto/Man mode switching, or Key lock parameter show/hide switching
- Number of input points: 2
- Input type: Non-voltage contact input or transistor open collector input
- Input contact rating:
  - 12 V DC, 10 mA or more (for non-voltage contact input)
- On/off detection:
  - For non-voltage contact input,
    - ON= contact resistance; 1 kΩ or less,
    - OFF= contact resistance; 20 kΩ or more.
  - For transistor open collector input,
    - ON= 2 V or less,
    - OFF= leakage current; 100 μA or less.
- Minimum retention time for status detection:
  - About 1 s

**Contact Outputs**

- Usage: Alarm output, FAIL output, and others
- Number of relay contact output points: 3
- Relay contact rating:
  - 240 V AC, 1 A or 30 V DC, 1 A
  - a-contact (COM terminals are common for every contact output.) (b-contact for FAIL output)

● **Display Unit Specifications**

- PV display: 4-digit, 7-segment green/red LED; each digit 12 mm in height
- Setpoint display:
  - 4-digit, 7-segment red LED; each digit 9.3 mm in height
- Status indicator lamps: LEDs

● **Conformance to Safety and EMC Standards**

Safety: Complies with IEC/EN61010-1 (CE), approved by C22.2 No.61010-1, approved by UL508.  
 Installation category : CAT. II Pollution degree: 2 (IEC/EN61010-1, C22.2 No.61010-1)  
 Measurement category : I (CAT. I : IEC/EN61010-1)  
 Rated measurement input voltage : 10V DC max.(across terminals), 300V AC max.(across ground)  
 Rated transient overvoltage : 1500V (Note)  
 Note : It is a value on the safety standard which is assumed by IEC/EN61010-1 in Measurement category I, and is not the value which guarantees an apparatus performance.  
 EMC standards: Complies with EN61326, EN61000-3-2, EN61000-3-3 and EN55011 (CE).  
 AS/NZS 2064 compliant (C-Tick).  
 Class A Group 1.  
 During test, the controller continues to operate with the measurement accuracy within ±20% of the range.

● **Construction, Mounting, and Wiring**

Construction: Dust-proof and Drip-proof front panel conforming to IP55.  
 For side-by-side close installation, the controller loses its dust-proof and drip-proof protection.  
 Material: ABS resin and polycarbonate  
 Case color: Black  
 Weight: About 1 kg or less  
 External dimensions:  
 48 (W) × 96 (H) × 100 (depth from the panel face) (mm)  
 Mounting: Direct panel mounting; mounting bracket, one each for upper and lower mounting  
 Panel cutout dimensions:  
 45<sup>+0.6</sup><sub>0</sub> (width) × 92<sup>+0.8</sup><sub>0</sub> (height) mm  
 Mounting attitude:  
 Up to 30 degrees above the horizontal. No downward tilting allowed.  
 Wiring: M3.5 (ISO 3.5 mm) screw terminals (signal wiring and power/ground wiring as well)

● **Power Supply and Isolation Specifications**

**Power Supply Specifications**

Power supply: Voltage rating at 100 to 240 V AC (±10%), 50/60 Hz  
 Power consumption: Max. 20 VA (Max. 8.0 W)  
 Internal fuse rating: 250 V AC, 1.6 A time-lug fuse  
 Memory back-up: Non-volatile memory (service life about 100,000 times of writings)  
 Withstanding voltage:  
 1500 V AC for 1 minute between primary and secondary terminals  
 1500 V AC for 1 minute between primary and ground terminals  
 1500 V AC for 1 minute between ground and secondary terminals.  
 500V AC for 1minute between two secondary terminals

( Primary terminals: Power supply and relay output terminals  
 Secondary terminals: Analog input/output signal terminals, voltage pulse output terminals, and contact input terminals )

Isolation resistance:  
 Between power supply and grounding terminals, 500 V DC 20 MΩ or more  
 Grounding: Class D grounding (Class 3 grounding) (grounding resistance of 100 Ω or less)

**Isolation Specifications**

PV input terminal:  
 Isolated from other input/output terminals.  
 Not isolated from internal circuits.  
 15 V DC loop power supply terminal:  
 Not isolated from 4-20mA analog output and voltage pulse control output. Isolated from other input/output terminals and internal circuit.  
 24 V DC loop power supply terminal:  
 Isolated from other input/output terminals and internal circuit.  
 Control output (current or voltage pulse) and retransmission terminal:  
 Not isolated between control output and retransmission output terminals. Isolated from other input/output terminals and internal circuits.  
 Relay contact control output terminal:  
 Isolated from other input/output terminals and internal circuits.  
 Contact input terminal:  
 Not isolated from other contact input terminals mutually, and from communication terminals. Isolated from other input/output terminals and internal circuits.  
 Relay contact alarm output terminal:  
 Isolated from other input/output terminals and internal circuits.  
 RS-485 communication terminal:  
 Not isolated from contact input terminals. Isolated from other input/output terminals and internal circuits.  
 Power supply terminal:  
 Isolated from other input/output terminals, grounding terminal, and internal circuits.  
 Grounding terminal:  
 Isolated from other input/output terminals, power supply terminals, and internal circuits.

● **Environmental Conditions**

Normal operating conditions:  
 Ambient temperature: 0 to 50°C (40°C or less when mounted side by side)  
 The operating ambient temperature range is between 0°C and 40°C when the 24 V DC loop power supply.  
 Ambient temperature change limit: 10°C/h or less  
 Ambient humidity: 20 to 90% RH (no condensation)  
 Magnetic field: 400 A/m or less  
 Continuous vibration (5 to 14 Hz):  
 Peak-to-peak amplitude of 1.2 mm or less  
 Continuous vibration (14 to 150 Hz):  
 4.9 m/s<sup>2</sup> or less  
 Short-period vibration: 14.7 m/s<sup>2</sup> or less, 15 s  
 Shock: 147 m/s<sup>2</sup> or less, 11 ms  
 Installation altitude: 2,000 m or less above sea level  
 Warm-up time: 30 minutes or more after power on  
 Transportation and storage conditions:  
 Temperature: -25 to 70°C  
 Temperature change limit: 20°C/h or less  
 Humidity: 5 to 95% RH (no condensation)  
 Effects of operating conditions  
 Effect of ambient temperature:  
 For voltage or TC input:  
 Equal to or less than whichever is greater, ±1 μV/°C or ±0.01% of F.S./°C.  
 For RTD inputs:  
 ±0.05°C/°C (ambient temperature) or less  
 For analog output:  
 ±0.05% of F.S./°C or less  
 Effect of power supply fluctuation (within rated voltage):  
 For analog input:  
 Equal to or less than whichever is greater, ±1 μV/10 V or ±0.01% of F.S./10 V.  
 For analog output:  
 ±0.05% of F.S./10 V or less

**Function Block Diagram for Standard Type**

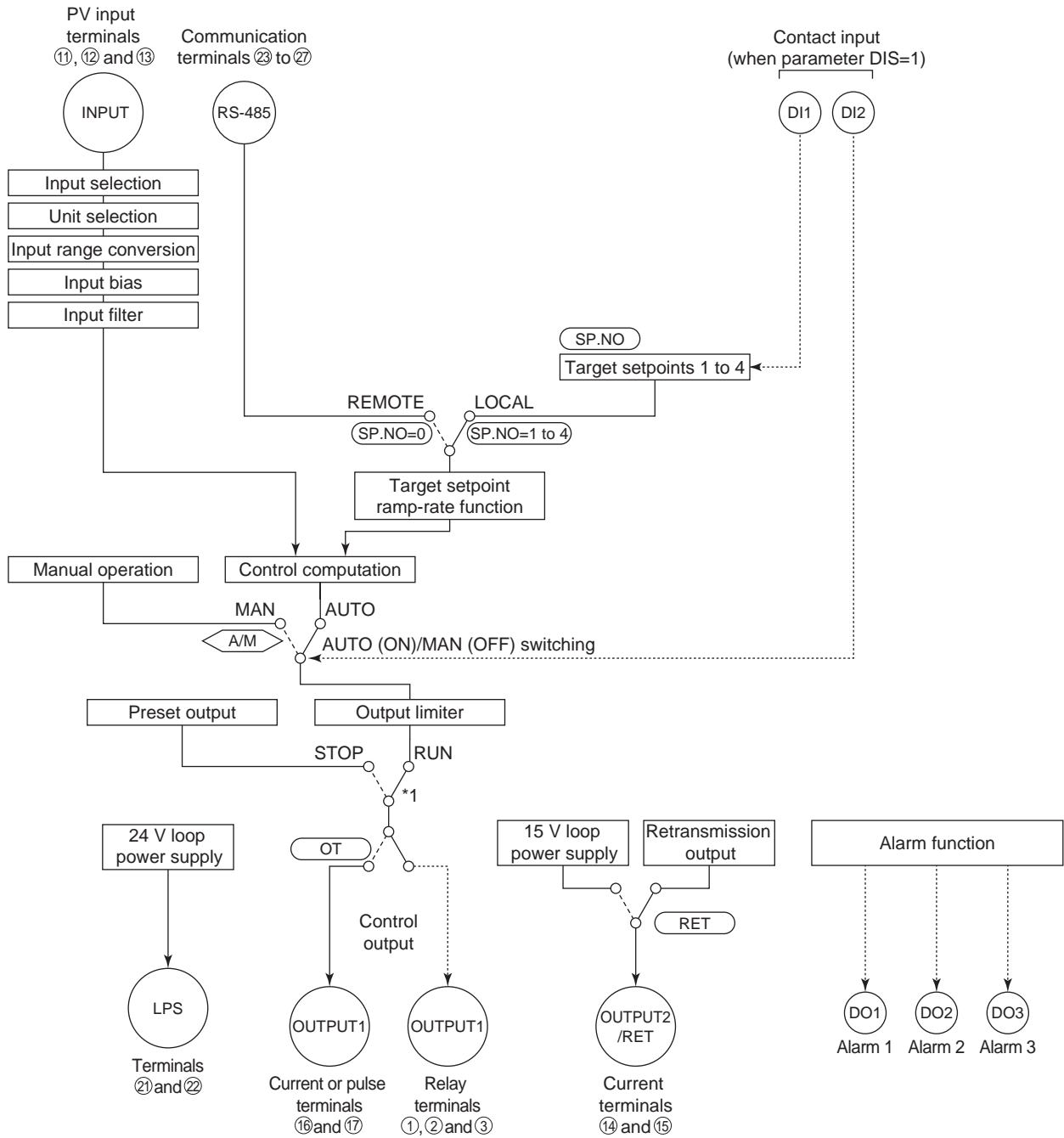

\*1: If the setup parameter DIS (DI function selection) is set to "4", when the contact input 2 is ON (STOP state), that controller outputs the preset output value.

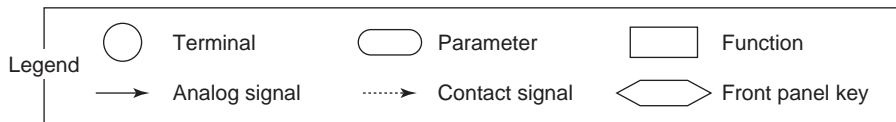



## Function Block Diagram for Heating/Cooling Type

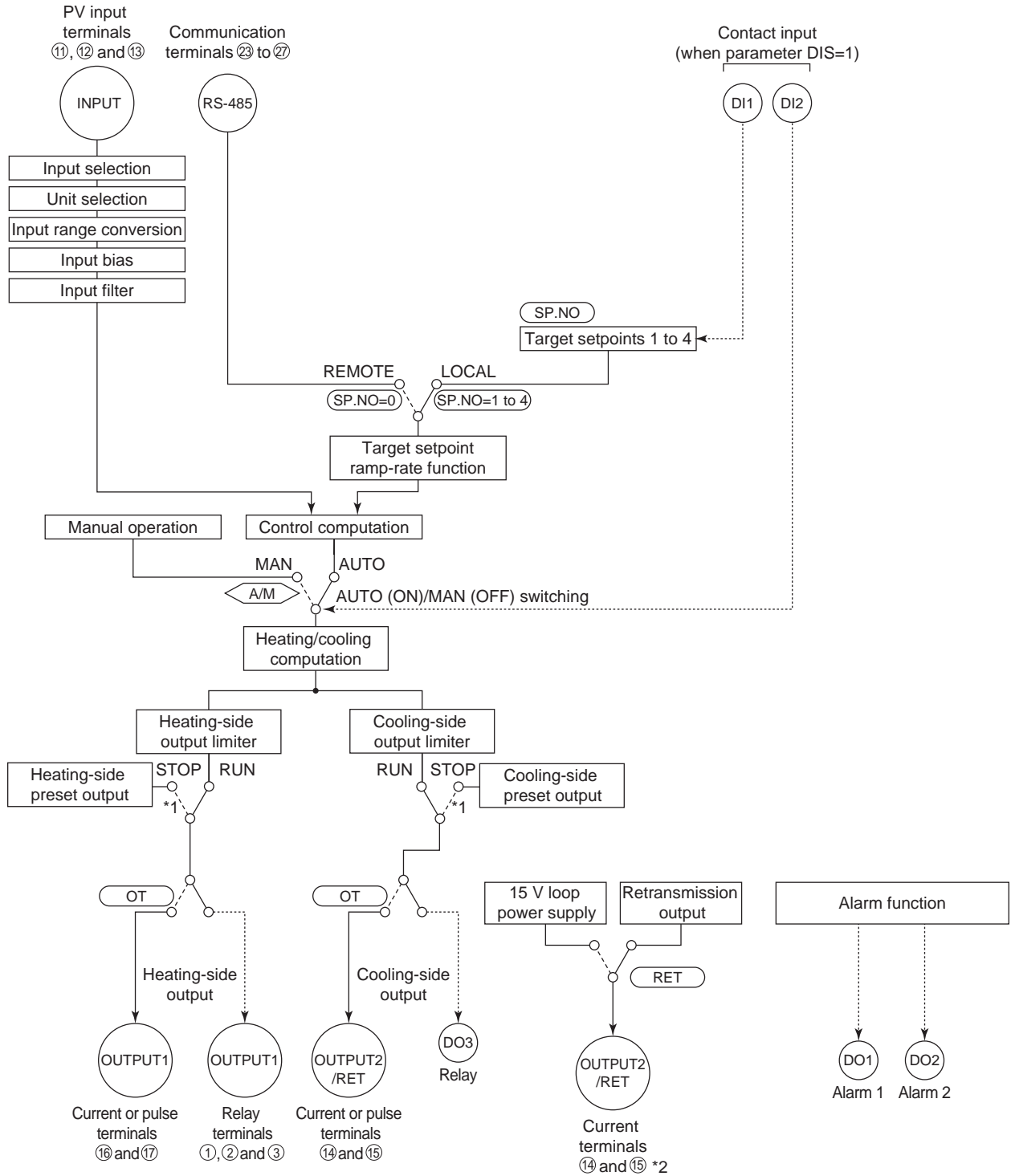

\*1: If the setup parameter DIS (DI function selection) is set to 4, when the contact input 2 is ON (STOP state), that controller outputs the preset output value.  
 \*2: Unavailable when cooling-side control output is current or pulse.

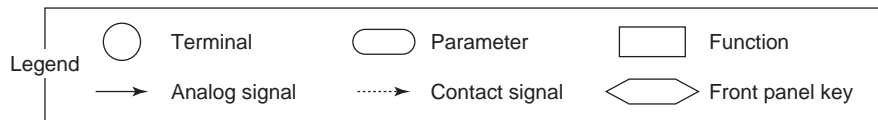

# Terminal Arrangements for Standard Type

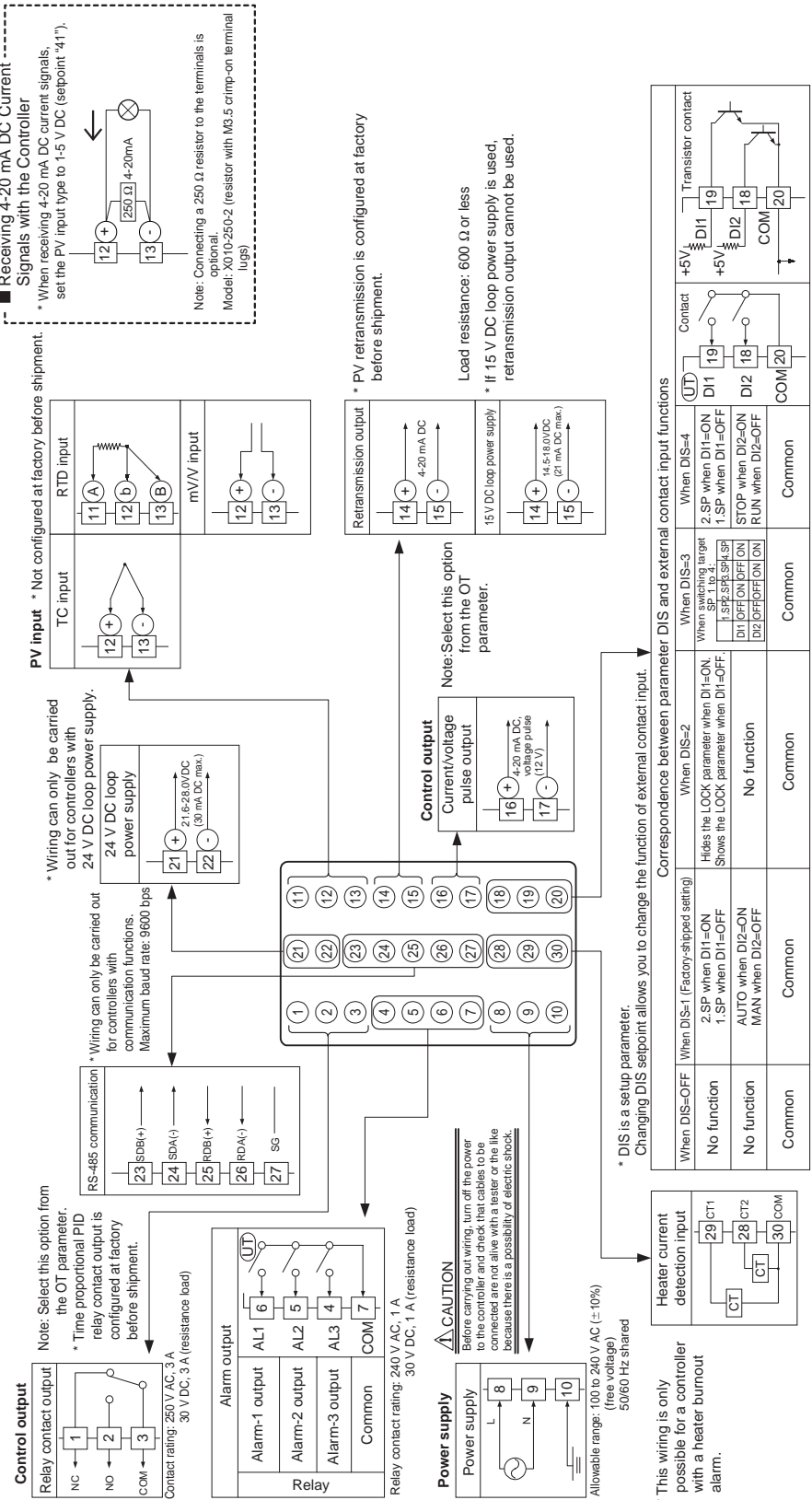

■ Receiving 4-20 mA DC Current Signals with the Controller  
 \* When receiving 4-20 mA DC current signals, set the PV input type to 1-5 V DC (setpoint "41").  
 Note: Connecting a 250 Ω resistor to the terminals is optional.  
 Model: X010-250-2 (resistor with M3.5 crimp-on terminal lug)

\* PV retransmission is configured at factory before shipment.  
 Load resistance: 600 Ω or less  
 \* If 15 V DC loop power supply is used, retransmission output cannot be used.

Note: External Contact Input  
 If the power is turned on when the external contact input is OFF, the mode (SP: NO or AM) existing before the power is turned off will be continued. (except for RUN/STOP)

\* OT is a setup parameter. You can change the settings of the parameter OT to change the control output type.  
 Correspondence between parameter OT and control output types

# Terminal Arrangements for Heating/Cooling Type

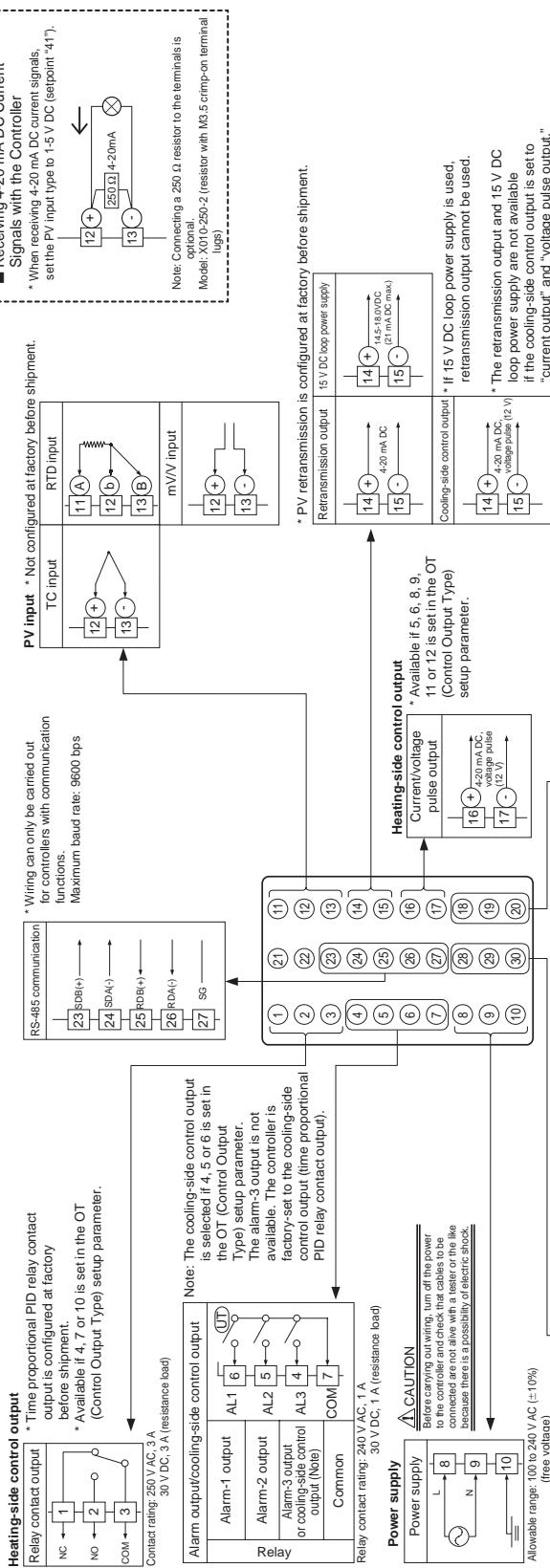

Changing DIS setpoint allows you to change the function of external contact input.

Correspondence between parameter DIS and external contact input functions			
When DIS=1 (Factory-shipped setting)	When DIS=2	When DIS=3	When DIS=4
When DIS=OFF	When DIS=ON	When DIS=ON	When DIS=ON
No function	2.SP when DI1=ON 1.SP when DI1=OFF	2.SP when DI1=ON 1.SP when DI1=OFF	2.SP when DI1=ON 1.SP when DI1=OFF
No function	AUTO when DI2=ON MAN when DI2=OFF	DI OFF COMPLETION DI2=OFF/ON	Transistor contact
Common	Common	Common	Common

Contract rating: 12 V DC, 10 mA or more

\* OT is a setup parameter. You can change the settings of the parameter OT to change the control output type.

Correspondence between parameter OT and heating-side/cooling-side output types	
OT=4 (factory-shipped setting)	OT=6
Heating side: Relay output (terminals ① and ②) Cooling side: Relay output (terminals ③ and ④)	Heating side: Current output (terminals ⑥ and ⑦) Cooling side: Current output (terminals ⑧ and ⑨)
OT=7	OT=9
Heating side: Relay output (terminals ① and ②) Cooling side: Voltage pulse output (terminals ③ and ④)	Heating side: Current output (terminals ⑥ and ⑦) Cooling side: Voltage pulse output (terminals ⑧ and ⑨)
OT=10	OT=12
Heating side: Relay output (terminals ① and ②) Cooling side: Current output (terminals ③ and ④)	Heating side: Current output (terminals ⑥ and ⑦) Cooling side: Current output (terminals ⑧ and ⑨)

The control output types, "relay output" and "voltage pulse output" shown in the table above refer to those of time proportional control. To change the type to a relay output for on-off control, select "Relay Terminals" and change the setpoint of the proportional band to "0."

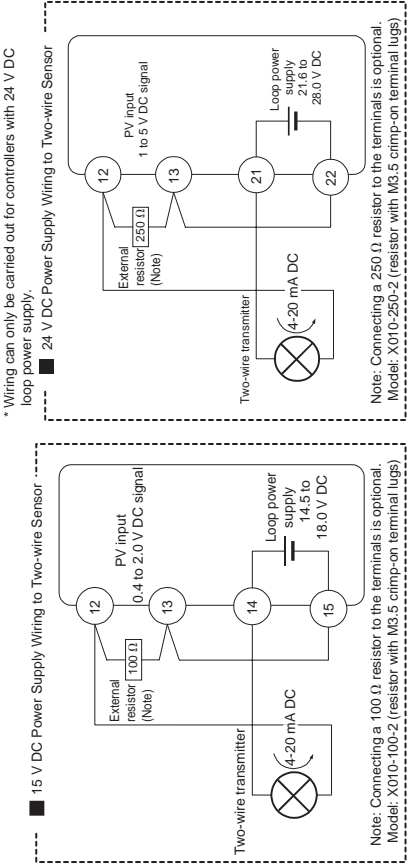

**External Dimensions and Panel Cutout Dimensions**

Unit: mm

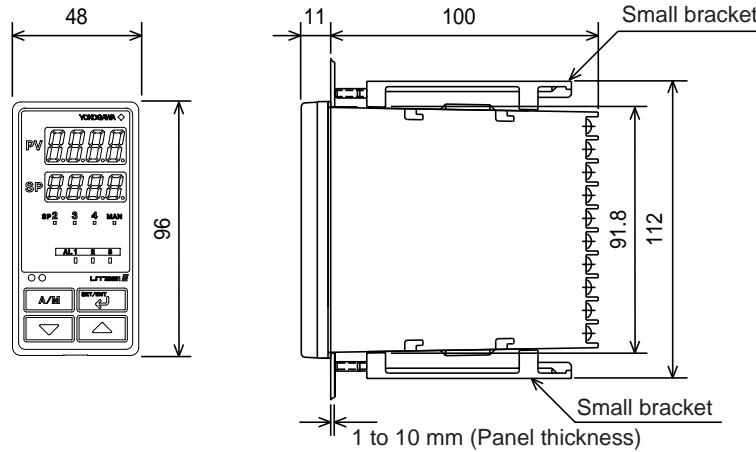

General installation

Side-by-side close installation

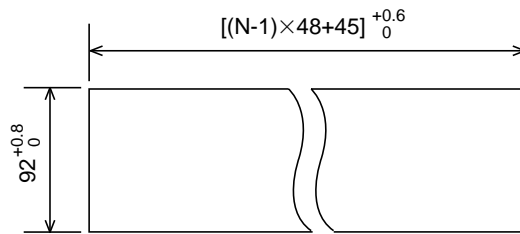
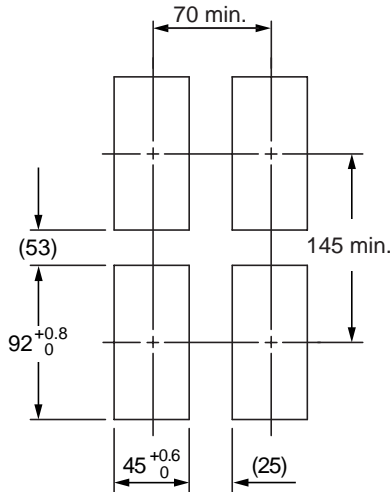

"N" stands for the number of controllers to be installed.  
However, the measured value applies if N ≥ 5.

Normal Allowable Deviation=± (Value of JIS B 0401-1999 tolerance grade IT18) / 2

**Model and Suffix Codes**

Model	Suffix Code	Description
UT321		Digital indicating controller (provided with retransmission output and 15 V DC loop power supply as standard)
Type	-0 -2 -3	Standard type Heating/cooling type Standard type (with 24 V DC loop power supply)
Optional functions	0 1 2	None With communication, heater burnout alarm With heater burnout alarm

Standard accessories: Brackets (mounting hardware), Unit label, User's manuals, and User's Manual (reference) (CD-ROM version)

Terminal cover (optional part) is provided.

**Items to be Specified when Ordering**

Model and suffix codes, necessary/unnecessary of User's Manual or QIC.